

(Legislative Supplement No. 41)

LEGAL NOTICE NO. 118

THE TRAFFIC ACT

(Cap. 403)

IN EXERCISE of the powers conferred by section 119 (1) of the Traffic Act, the Minister for Transport makes the following Rules:—

THE TRAFFIC (AMENDMENT) RULES, 2008

1. These rules may be cited as the Traffic (Amendment) Rules, 2008 and shall come into force on 1st October, 2008.

2. Rule 41 of the Traffic Rules, in these rules referred to as “the principal Rules”, is amended in sub-rule (2) by deleting all the items appearing immediately after the words “following scale” and substituting therefor the following:

<i>Degree of Each Axle Overloading or Excess Gross Vehicle Weight in Kilograms (kg.)</i>	<i>Fine (KSh.)</i>	
	<i>Fine on First Conviction (KSh.)</i>	<i>Fine on Second or Subsequent Conviction (KSh.)</i>
Less than 1,000 kg.	5,000	10,000
1,000 kg. or more but less than 2,000 kg.	10,000	20,000
2,000 kg. or more but less than 3,000 kg.	15,000	30,000
3,000 kg. or more but less than 4,000 kg.	20,000	40,000
4,000 kg. or more but less than 5,000 kg.	30,000	60,000
5,000 kg. or more but less than 6,000 kg.	50,000	100,000
6,000 kg. or more but less than 7,000 kg.	75,000	150,000
7,000 kg. or more but less than 8,000 kg.	100,000	200,000
8,000 kg. or more but less than 9,000 kg.	150,000	300,000
9,000 kg. or more but less than 10,000 kg.	175,000	350,000
10,000 kg. or more	200,000	400,000

3. The Twelfth Schedule to the principal Rules is amended—

- (a) by deleting the words “WEIGHTS AND DIMENSIONS OF VEHICLES” and substituting therefor the following—

“PART 1—WEIGHTS AND DIMENSIONS OF VEHICLES”.

(b) in paragraph 2—

(i) by deleting all the items appearing after the word “exceed” in subparagraph (1) and substituting therefor the following—

- | | |
|---|-----------------|
| “(a) by way of any single axle fitted with four or more wheels. | 10,000 kg. |
| (b) by way of any single steering axle, whether controlled by a drawbar or driver operated steering mechanism | 8,000 kilograms |
| (c) by way of any a tandem axle group having four wheels on each axle .. | 16,000 kg. |
| (d) by way of a triple axle group having four wheels on each axle .. | 24,000 kg. |

Provided that in the case of any axle or axle group (excluding a single steering axle) where one or more of the axles is fitted with only two wheels, the appropriate maximum allowable load figure given in this subparagraph shall be reduced by twenty-five per cent.”

(ii) by deleting all the items appearing after the word “following” in subparagraph (2) and substituting therefor the following—

- | | |
|--|------------|
| (a) vehicle with two axles | 18,000 kg. |
| (b) vehicle with three axles | 24,000 kg. |
| (c) vehicle and semi-trailer with total of three axles | 28,000 kg. |
| (d) vehicle with four axles | 28,000 kg. |
| (e) vehicle and semi-trailer with total of four axles | 34,000 kg. |
| (f) vehicle and drawbar trailer with total of four axles | 36,000 kg. |
| (g) vehicle and semi-trailer with total of five axles | 42,000 kg. |
| (h) vehicle and drawbar trailer with total of five axles | 42,000 kg. |
| (i) vehicle and semi-trailer with total of six axles | 48,000 kg. |
| (j) vehicle and drawbar trailer with total of six axles | 48,000 kg. |

(iii) by deleting subparagraphs (6), (7), (8) and (9) and substituting therefor the following new subparagraphs—

“(6) Where the application of the provisions of subparagraph (2) result in two or more different weights being applicable to a particular vehicle, the lower or the lowest weight shall be the maximum weight of that vehicle for the purpose of section 55 (2) of the Act”

“(7) No vehicle with a rigid chassis shall have more than three axles except for a vehicle with two steering axles and two rear axles.”

“(8) The maximum number of axles which may be fitted on any combination of a motor vehicle and a semi-trailer or motor vehicle and drawbar trailer shall be six.

“(9) The maximum number of axles in any axle group fitted on any trailer shall not exceed—

- (a) on a drawbar trailer, 2 axles; and,
- (b) on a semi-trailer, 3 axles.”

(c) by inserting the following new Part immediately after paragraph 9—

“PART II—VEHICLE AXLE CONFIGURATION

Diagram 1: Rigid Body Vehicle – 2 Axles [paragraph 2 (2) (a)]

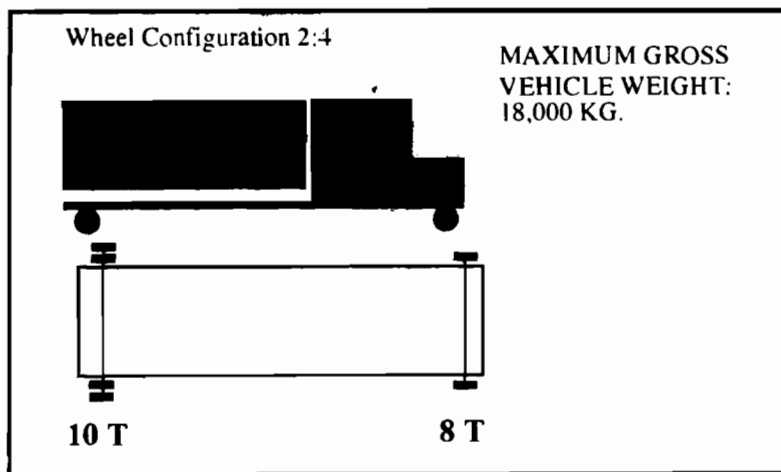

Diagram 2: Rigid Body Vehicle – 3 Axles

[paragraph 2(2)(b)]

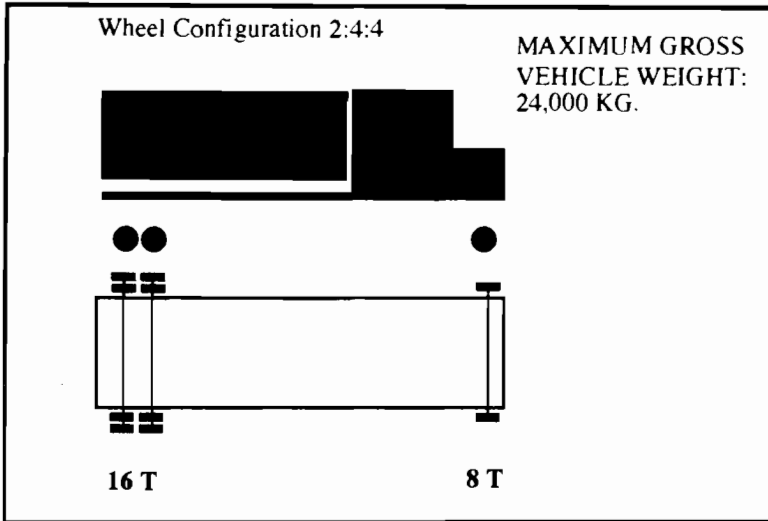

Diagram 3: Vehicle & Semi-Trailer – 3 Axles

[paragraph 2 (2) (c)]

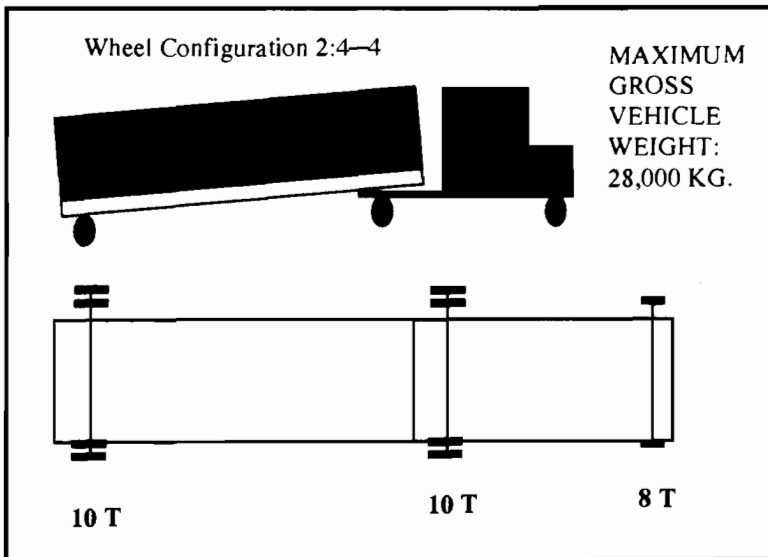

Diagram 4: Rigid Body Vehicle – 4 Axles [paragraph 2 (2) (d)]

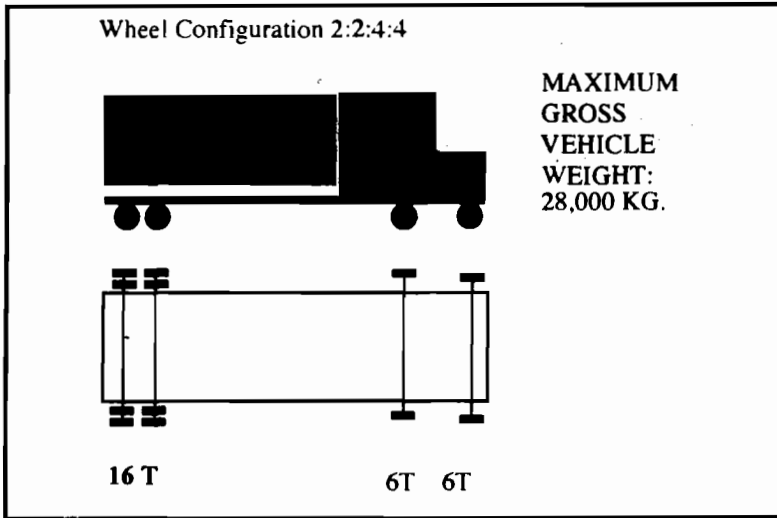

Diagram 5: Vehicle & Semi-trailer – 4 Axles [paragraph 2 (2) (e)]

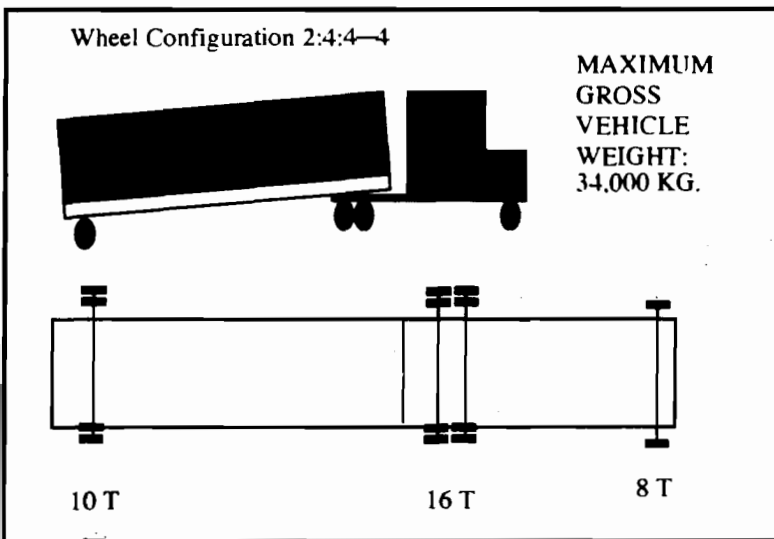

Diagram 8: Vehicle & Semi-trailer – 5 Axles

[paragraph 2(2)(g)]

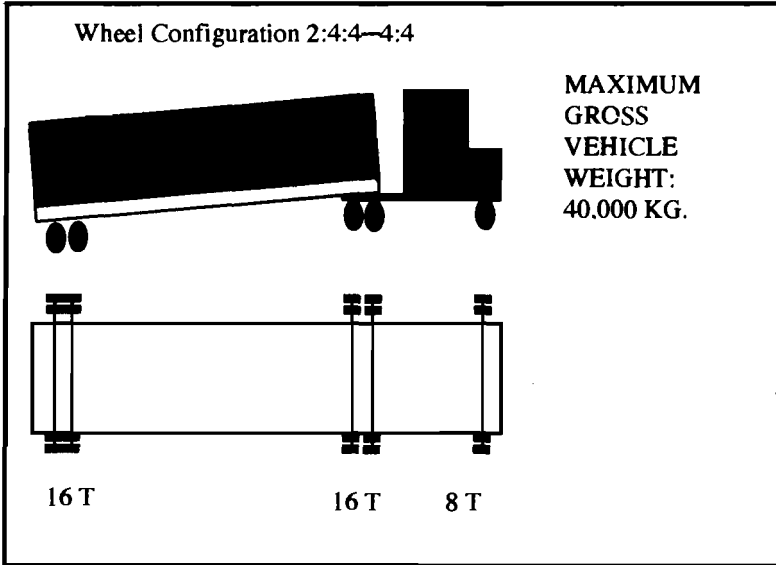

Diagram 9: Vehicle & Semi-trailer – 5 Axles

[paragraph 2(2)(g)]

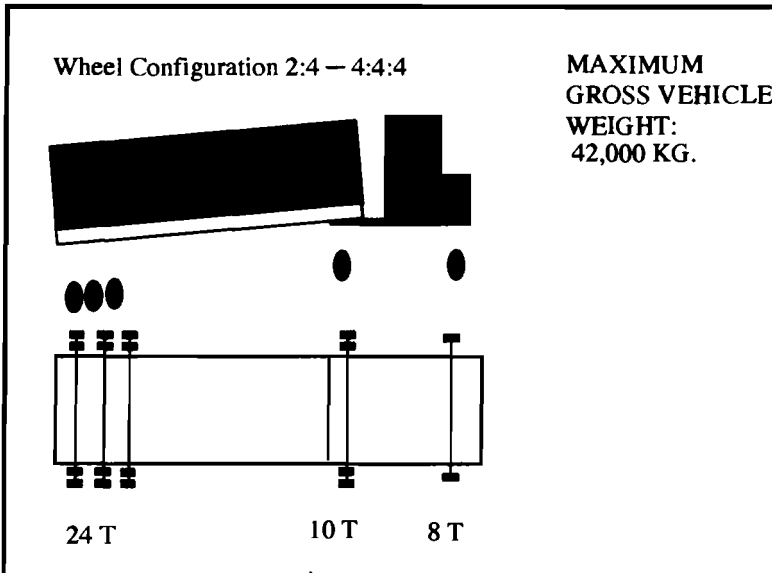

Diagram 10: Vehicle & Drawbar Trailer – 5 Axles [paragraph 2 (2) (h)]

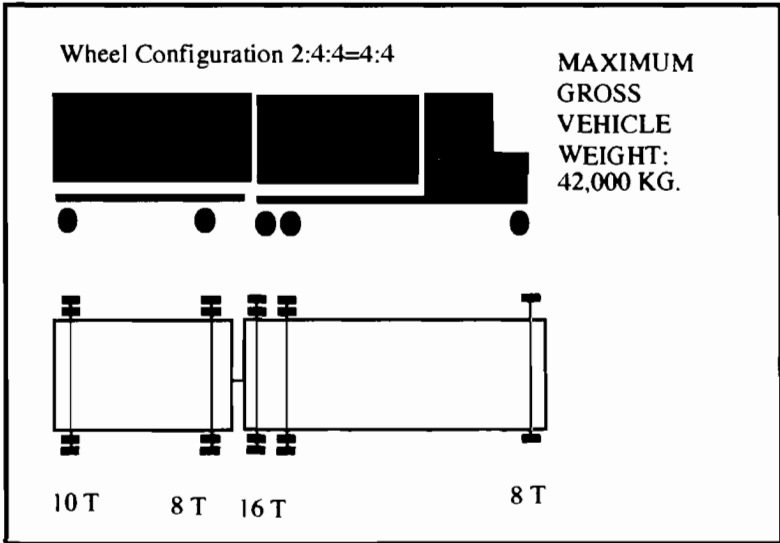

Diagram 11: Vehicle & Semi-trailer – 6 Axles [paragraph 2 (2) (i)]

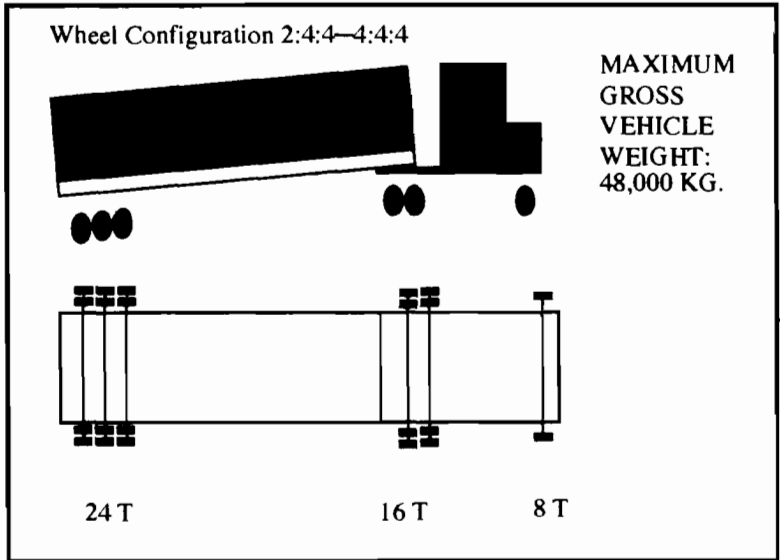
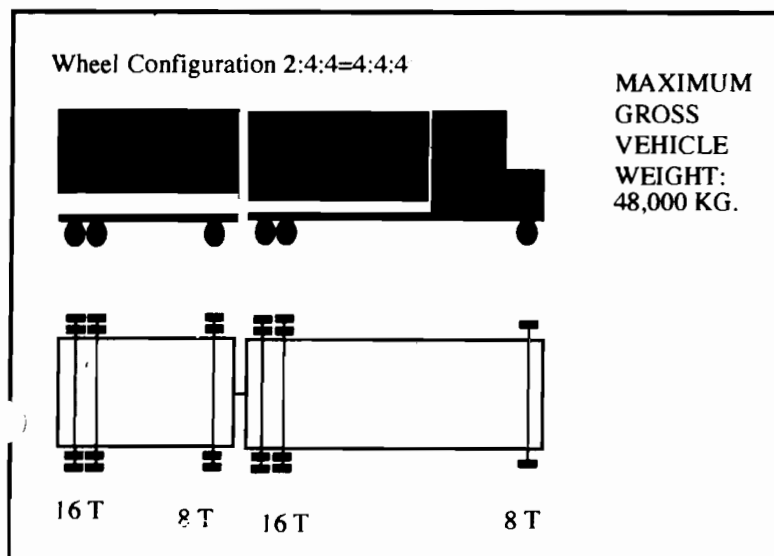

Diagram 12: Vehicle & Drawbar Trailer – 6 Axles [paragraph 2 (2) (j)]”



Dated the 15th August, 2008.

C. A. MWAKWERE,
Minister for Transport.

LEGAL NOTICE NO. 119

THE TRAFFIC ACT

(Cap. 403)

EXEMPTION

IN EXERCISE of the powers conferred by section 120 of the Traffic Act, the Minister for Transport exempts the vehicles described hereunder from the provisions of Section 55 (2) of the Act and Rule 41 (1) of the Traffic Rules:

<i>Chassis No.</i>	<i>Make</i>	<i>Type</i>
8/N ISMSL8H5MWYIDF111	M1000 HET	Low Loader

This exemption shall be deemed to have come into force on 26th August, 2008.

Dated the 26th August, 2008.

C. A. MWAKWERE,
Minister for Transport.